

OFFSET ADVANTAGE

10,000 LB VERSYMMETRIC® 2-POST SERIES

Service more vehicles and increase your bottom line with Challenger's flagship CL10 series 2-post lifts. Our exclusive Versymmetric® Technology provides the versatility to safely lift vehicles symmetrically or asymmetrically within the same service bay.



CL10V3
10,000 LB. CAPACITY
» Versymmetric®
2-post lift



CL10V3-DPC
10,000 LB. CAPACITY
» Versymmetric®
2-post lift with dual
pendant controls



CL10V3-QC
10,000 LB. CAPACITY
» Versymmetric®
2-post lift with
Quick Cycle



CL10-XP9
9,000 LB. CAPACITY
» Versymmetric® 2-post
lift with drive-on
express pad

Versymmetric®
Technology

CL Challenger Lifts

FEATURES & BENEFITS

- » Exclusive Versymmetric® offset arms provide directSPOT™ to vehicle lift points and safely lifts both symmetrically and asymmetrically within the same service bay
- » Oversized 5" diameter pulley and heavy duty 5/16" cable reduces stress on equalization system and increases cable life
- » 48" elongated carriage design increases lift life
- » Standard model fits 12' ceiling height. Additional 2 foot or 3 foot extensions available
- » Padded overhead shut off system prevents vehicle damage
- » Premium double telescoping screw pads adjust to multiple heights minimizing the need for adapters
- » Fully gusseted base plate design increases column rigidity
- » Pulley-less jacketed single-point lock release system makes for smoother, easier operation and longer life
- » Standard dual integrated rubber door guards help protect vehicle panels from inadvertent damage
- » Plated arm restraints and arm pins inhibit rust and provide long-lasting durability
- » Premium powder coat finish provides long-lasting durability
- » Double telescoping screw pads adjust from 3.875" to 6.125," reducing the need for adapters



CL10V3

10,000 LB. CAPACITY

» Versymmetric® 2-post lift



ARM CONFIGURATIONS

- » Industry-first 2-post lift with directSPOT™ 3-stage offset front and 3-stage rear arms for single-sweep spotting. Eliminate the need to roll a vehicle back and forth in order for the front arm to clear the tire
- » Maximum arm sweep, reach and retraction meet the widest range of recommended lifting points

ONE ATTEMPT SPOTTING

CL10V3 comes standard with offset 3-stage front arms, which can be retracted in an asymmetric lifting position rear of the front tires. Unlike many competing lifts, when the vehicle is driven through, the front arms are capable of directSPOT™ to the vehicle's lifting point without having to reposition the vehicle or shuffle back and forth to reach its recommended lift points.

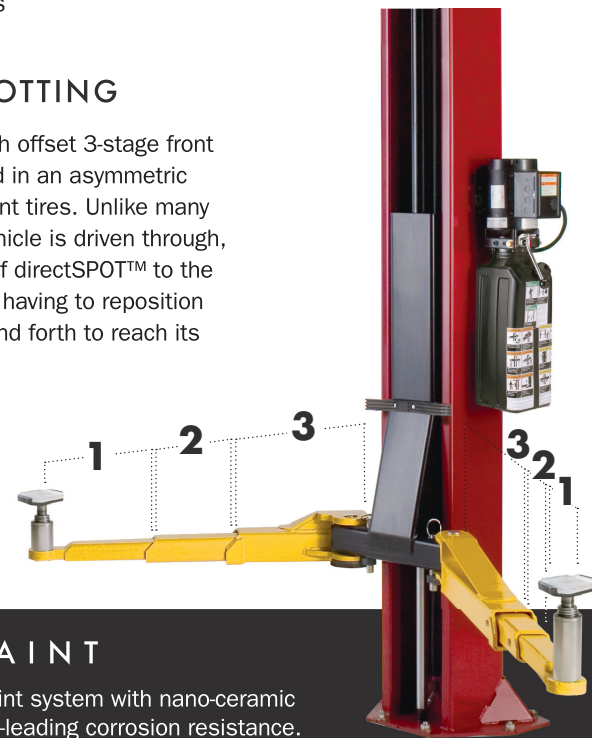

SUPERIOR PAINT

Challenger's powder coat paint system with nano-ceramic technology provides industry-leading corrosion resistance. The CL10 series comes standard in red, blue or black durable powder coat paint. Custom colors are also available. Contact factory for more details.

FEATURES



Factory-installed rubber door guard protection



48" carriage with (8) slide bearing blocks reduce stress

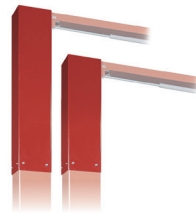

Optional 2' or 3' column extensions for high profile vehicles



5" pulley diameter versus competition



Double telescoping screw adjusts from 3.875" to 6.125" and has removable rubber pad



Gusseted base plate requires a minimum of 4" reinforced concrete at 3500 psi

VELOCITY EXPRESS SERVICE LIFT

Challenger's 9,000 lb. capacity drive-on express pad features flip-up ramps that mount to our CL10 2-post lift.

The Velocity Lift is a quick vehicle spotting solution perfect to meet express service needs such as quick lube applications, tire rotations, tire balancing, brake work, inspection check lanes and any other general service need where efficiency is essential.

Quick Cycle Technology reduces the rise and descent time of the Velocity Lift by 30 percent, while our Dual Pendant Controls provide expedited vehicle spotting from either column with an unobstructed view of lift points. Express service lifts come standard with (4) 1.5" and (4) 3" rubber spotting blocks.

Take advantage of Challenger's premier 10,000 lb. capacity 2-post lift and enjoy the fastest return on your investment.

FEATURES & BENEFITS

- » Drive-on style pad provides quick vehicle spotting for express bays
- » Low-profile pad design minimizes vehicle clearance issues
- » Reinforced front and rear access ramps are designed to easily flip up and lock to extend the platform to accommodate longer wheelbase vehicles
- » Standard column-mounted spotting block storage caddy helps keep a safe and clean work environment

**PERFECT FOR QUICK-SERVICE
AND EXPRESS APPLICATIONS**



CHALLENGER VELOCITY

CL10-XP9-DPC-QC

9,000 LB. CAPACITY

- » 2-post lift with drive-on pad

Shown with optional accessories

DRIVE-ON EXPRESS SERVICE PAD



STANDARD ADAPTERS



(4) 1.5" rubber
spotting blocks



(4) 3" rubber
spotting blocks

STANDARD & QC

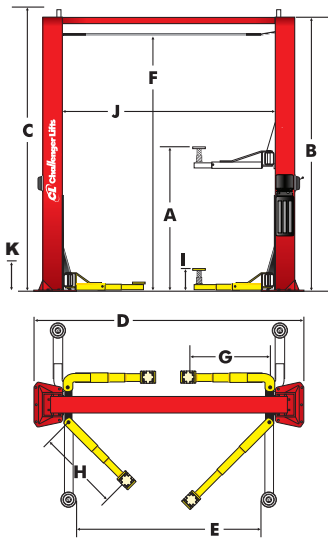

DPC MODELS

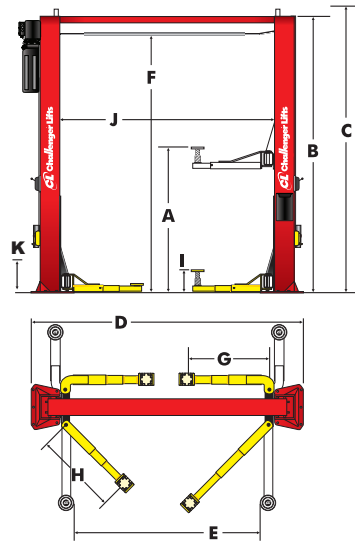

XP9 MODELS

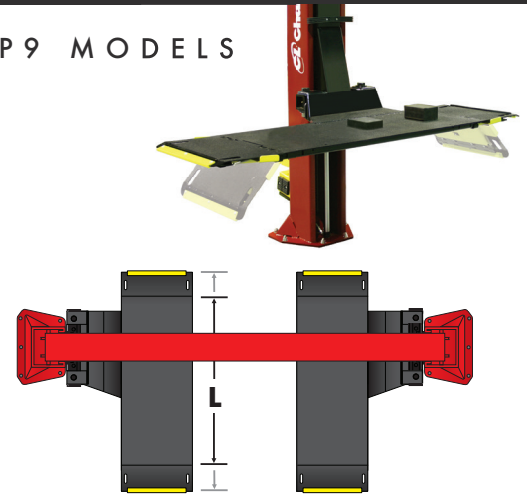

CL10V3 and CL10-XP9 lifts are available with either Dual Pendant Controls, Quick Cycle Technology or both

Model Number	CL10V3	CL10V3-QC	CL10-XP9	CL10-XP9-QC
Lifting Capacity*	10,000 lbs.		9,000 lbs.	
Lifting Configuration	Versymmetric (3-stage front/rear)		Drive-on Express Pad	
A Rise Height ¹	74.125"		70"	
B Column Height	Standard 11' 8" / with 2' extension: 13' 8" / with 3' extension: 14' 8"			
C Cylinder Overall (Full Stroke)	11' 11"			
D Adjustable Width Overall	11' 6.5" - 11' 11"			
E Drive-Thru Clearance	100" / 104.5"		79.5"	
F Floor to Overhead Switch	134.5" / with 2' extension: 158.5" / with 3' extension: 170.5"			
G Front Arm Reach (Min./Max.)	20" / 42"		-	
H Rear Arm Reach (Min./Max.)	37.625" / 60"		-	
I Screw Pad Height	3.875" / 6.125"		-	
J Inside Columns	110" / 114.5"		-	
K Low Lock Height	12" net rise			
L Platform Length	-		58"/66.5"/75"	
Motor / Voltage*	2HP, 208v-230v	3HP, 208v-230v	2 HP, 208v-230v	3HP, 208v-230v
Speed of Rise	38 s	27 s	38 s	27 s
Max. Load Per Arm	2,500 lb.		4,500 lb. per platform	
Ceiling Height Required	11' 11" / with 2' extension: 13' 9" / with 3' extension: 14' 9"			
ALI certified	√	√	√	√
Colors Available				

¹Rise height is measured including tall (6") stack adapters * Single phase standard

For more information, contact your Authorized Challenger Lifts Distributor:



AAIA
Automotive Aftermarket
Industry Association



The Automotive Lift Institute (ALI) certifies that the CL12 described herein complies with the applicable provisions of the American National Standards ANSI/ALI ALCTV 2011 and is Third Party Validated by the ETL Testing Laboratory.

800-648-5438 | 502-625-0700 | Fax: 502-625-0711 | Email: sales@challengerlifts.com | 2311 South Park Road | Louisville, KY 40219